

# INSTALLATION MANUAL

## *E-Series*

### MODELS

ES-6500V

ES-6500P

ES-6500W

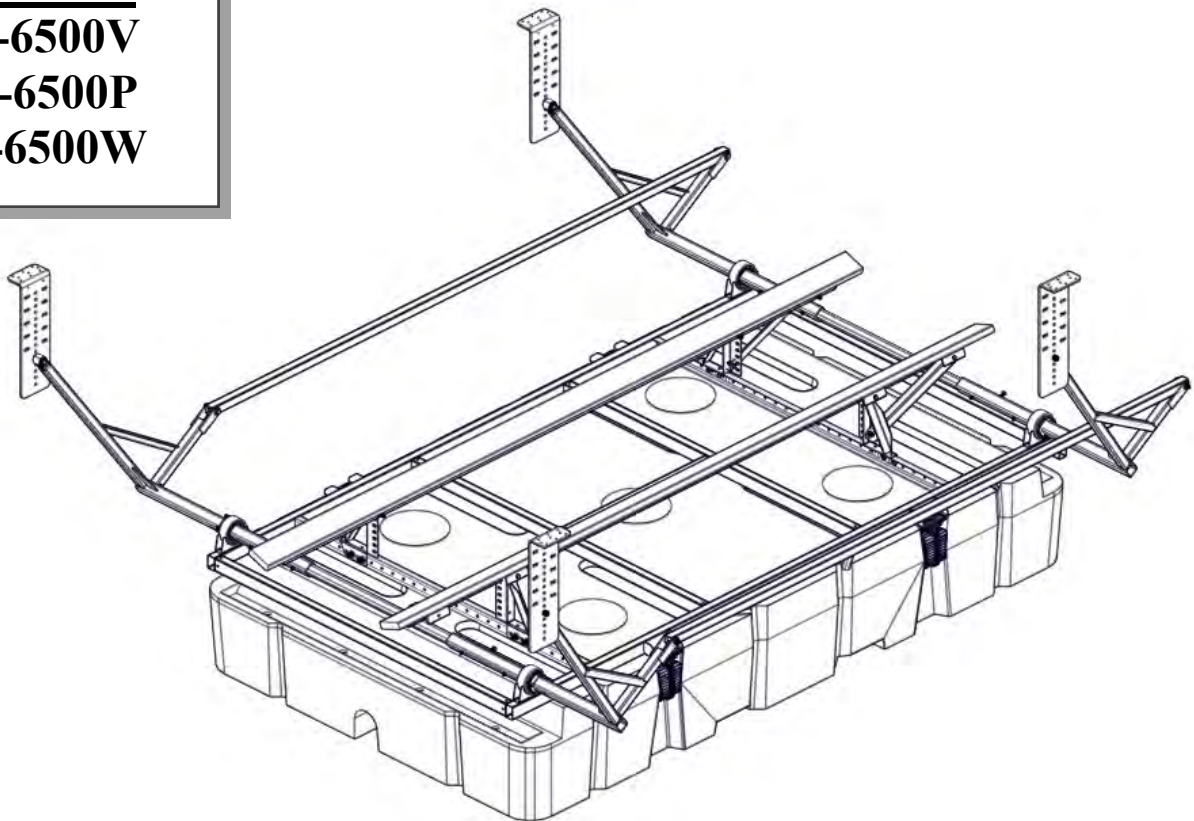

*HydroHoist Marine Group, Inc.*  
915 W. Blue Starr Dr. Claremore, OK 74017  
1-800-825-3379

®

Pub. May, 2014

## **HydroHoist Marine Group Product Installation and Use Warning Disclaimer**

ASSEMBLY, INSTALLATION OR REPAIRS OF A HYDROHOIST BOAT LIFT SHOULD ONLY BE PERFORMED BY AN AUTHORIZED HYDROHOIST TECHNICIAN. IF ASSEMBLY, INSTALLATION AND/OR REPAIR IS PERFORMED BY UNAUTHORIZED PERSONS, SERIOUS PERSONAL INJURY AND/OR PROPERTY DAMAGE COULD OCCUR.

IF UNAUTHORIZED PERSONNEL ASSEMBLE, INSTALL OR REPAIR A HYDROHOIST BOAT LIFT, HYDROHOIST MARINE GROUP HEREBY DISCLAIMS ANY AND ALL WARRANTIES, EXPRESS OR IMPLIED. HYDROHOIST MARINE GROUP LIMITS ITS WARRANTY TO HYDROHOIST MARINE GROUP'S PUBLISHED BOATLIFT WARRANTY FURNISHED WITH EACH PRODUCT. NO OTHER WARRANTY OF ANY KIND EITHER VERBALLY OR IMPLIED INCLUDING WARRANTIES OF MERCHANTABILITY AND FITNESS FOR A PARTICULAR PURPOSE ARE RECOGNIZED.

THE CONTENTS OF THIS MANUAL ARE SUBJECT TO CHANGE WITHOUT NOTICE AND SHOULD NOT BE CONSTRUED AS A COMMITMENT, REPRESENTATION, WARRANTY OR GUARANTEE OF ANY METHOD, PRODUCT OR DEVICE BY HYDROHOIST MARINE GROUP.

REPRODUCTION OR TRANSLATION OF ANY PART OF THIS MANUAL, WITHOUT THE WRITTEN PERMISSION OF HYDROHOIST MARINE GROUP IS PROHIBITED.

ANY INQUIRIES CONCERNING HYDROHOIST MARINE GROUP'S PUBLISHED WARRANTY OR THIS MANUAL AND ITS CONTENTS SHOULD BE REFERRED TO:

CUSTOMER SERVICE  
HYDROHOIST MARINE GROUP  
915 WEST BLUE STARR DRIVE  
CLAREMORE, OK USA 74017  
PHONE 918-341-6811  
OFFICE HOURS M-F 8AM TO 5PM CT

## **HydroHoist Marine Group Safety Notice**

TO ENSURE CONSUMER SAFETY, HYDROHOIST MARINE GROUP HAS INSTALLED IN THE CONTROL UNIT'S ELECTRICAL SYSTEM AN AC GROUND FAULT CIRCUIT INTERRUPTER (GFCI) DEVICE WHICH IS TO BE USED IN SERIES WITH THE USER'S PRIMARY AC POWER SOURCE. THE GFCI IS AN INTEGRAL PART OF THE HYDROHOIST BOAT LIFT AND IS DESIGNED TO OFFER A LIMITED MEASURE OF PROTECTION TO THE USER AGAINST HAZARDOUS ELECTRICAL CONDITIONS OR SHOCKS SHOULD THEY OCCUR.

THE USER SHOULD BE AWARE OF THE FOLLOWING WARNING:

### **WARNING!**

**IF USER DISABLES THE CONTROL UNIT'S GROUND FAULT CIRCUIT INTERRUPTER (GFCI) DEVICE, HE IS IN DIRECT CONFLICT WITH THE RECOMMENDATIONS OF THE UNITED STATES GOVERNMENT CONSUMER PRODUCTS SAFETY COMMISSION. DISABLING THE GFCI COULD RESULT IN SEVERE ELECTRICAL SHOCK OR DEATH.**

**BEFORE CONNECTING AC POWER TO THE CONTROL UNIT, BE CERTAIN THAT THE PRIMARY AC POWER SUPPLY MEETS ALL APPLICABLE ELECTRICAL CODES.**

ANY INQUIRIES CONCERNING THE GROUND FAULT CIRCUIT INTERRUPTER (GFCI) DEVICE SHOULD BE REFERRED TO:

CUSTOMER SERVICE  
HYDROHOIST MARINE GROUP  
915 WEST BLUE STARR DRIVE  
CLAREMORE, OK USA 74017  
PHONE 918-341-6811  
OFFICE HOURS M-F 8AM TO 5PM CT

# CONTENTS

**Getting Started - *Section 1***

**Site Preparation - *Section 2***

**Assembly - *Section 3***

**Installation - *Section 4***

**Parts List - *Section 7***

# Getting Started

## Assembly Platform

Assembly is best performed on a flat, level surface.

A flat-bed trailer is preferred, but a boat trailer with planks across the frame will work, provided that the assembly surface is flat and level

## Tools

A list of tools needed for hoist assembly is given below. In addition to these, tools for boat dock preparation, dock bumper removal, etc. may also be required.

- ◆ 1/2" Drive Ratchet (minimum 9 inch handle length for leverage)
- ◆ Electric Drill
- ◆ 3/4" Deep Well Socket
- ◆ 9/16" Deep Well Socket
- ◆ (2) 15/16" Open-end or Combination Wrenches
- ◆ 3/4" Open-end or Combination Wrenches
- ◆ 9/16 Open-ended or Combination Wrenches
- ◆ (2) Come-A-Longs
- ◆ 5/16" Nut Runner or medium blade Slotted Screwdriver
- ◆ Medium Phillips Screwdriver
- ◆ Drift Pin or other hole aligning tool
- ◆ Large Hammer (3 or 4 lb. shop hammer is best)
- ◆ Knife or tool for cutting 1" rubber hose
- ◆ Measuring Tape
- ◆ 3/4" Ratcheting Open-end Wrench
- ◆ Crescent or Pipe wrench

## Symbols & Conventions

All references to the LEFT or RIGHT are considered to be facing forward, as if driving a boat into the slip. Left is Port side, Right is Starboard side.  
Parts are occasionally described as LEFT or RIGHT to identify their opposing construction, not location on the hoist.

All numbers in brackets [ ] after part names refer to the item numbers on the assembly illustrations within the manual.

# Site Preparation

<b>Verify</b>	The Boat Stall or Mooring Location. ♦ If the hoist is being installed in a commercial marina or multi-slip boat dock, confirm the correct mooring location for hoist and boat.
	The boat specifications. ♦ Make _____ ♦ Model _____ ♦ Length (without swim platform) _____ ♦ Beam _____ ♦ Dry Weight of boat _____ lbs. ♦ Fuel: _____ gal. @ 6.6 lbs./gal. = _____ lbs. ♦ Water: _____ gal. @ 7.5 lbs./gal. = _____ lbs. ♦ Gear estimated @ 8% of boat's dry weight _____ lbs. ♦ Other equipment or weight _____ lbs. ♦ TOTAL LIFTING WEIGHT _____ LBS.

<b>Inspect</b>	The boat slip, dock or seawall to which the hoist will be installed.
	♦ The structure should be of good, sturdy construction capable of maintaining a secure mooring for the hoist.
	♦ The E-Series by HydroHoist requires a minimum water depth of <b>42" Plus the draft of the hull</b> . Confirm that there is sufficient water depth at all times of the year.
	♦ Check for underwater obstructions, such as structural braces, cables, rocks, or sunken objects which will interfere with the hoist's operation.
	♦ Check for overhead obstructions and confirm that sufficient clearance exists for the lifting of the boat. Boats vertical rise will be approximately 12" - 24" plus the boats Hull Draft, depending on the weight of the boat.
	♦ Confirm that electrical supply is available and sufficient for hoist operation. The control unit requires 115V and 11 amps.
	♦ Confirm that sufficient dock space is available for mooring the hoist and boat.
	♦ <b>CONFIRM THE BOAT HULL CONFIGURATION - Boats with a stepped hull design, or with through-the-hull apparatus, may require special positioning or alteration to the Hull Support Pads. Contact HydroHoist Engineering Department if proper hull support is in question.</b>

---

# Assembly Instructions

**Description** The assembly instructions presented within this section represent the steps for assembling E-Series by HydroHoist Boat Lift. It is recommended that before assembling the components, you read and understand each procedural step to become familiar with how all parts are assembled.

**Tightening of Fasteners** In the assembly procedures, DO NOT TIGHTEN fasteners until directed to do so. Insert bolts with appropriate washers, lock washers and nuts; unless otherwise instructed, leave the fasteners loose to allow movement of the parts for adjustment during assembly. Tighten all bolts at finish of assembly - proper torque specifications for bolts are listed below:

BOLT SIZE	FOOT POUNDS OF TORQUE
1/4-20	5 FT. LBS.
5/16-18	11 FT. LBS.
3/8-16	18 FT. LBS.
7/16-14	28 FT. LBS.
1/2-13	39 FT. LBS.
9/16-12	51 FT. LBS.
5/8-11	83 FT. LBS.

---

# V-Hull and Wake Boat Diagram

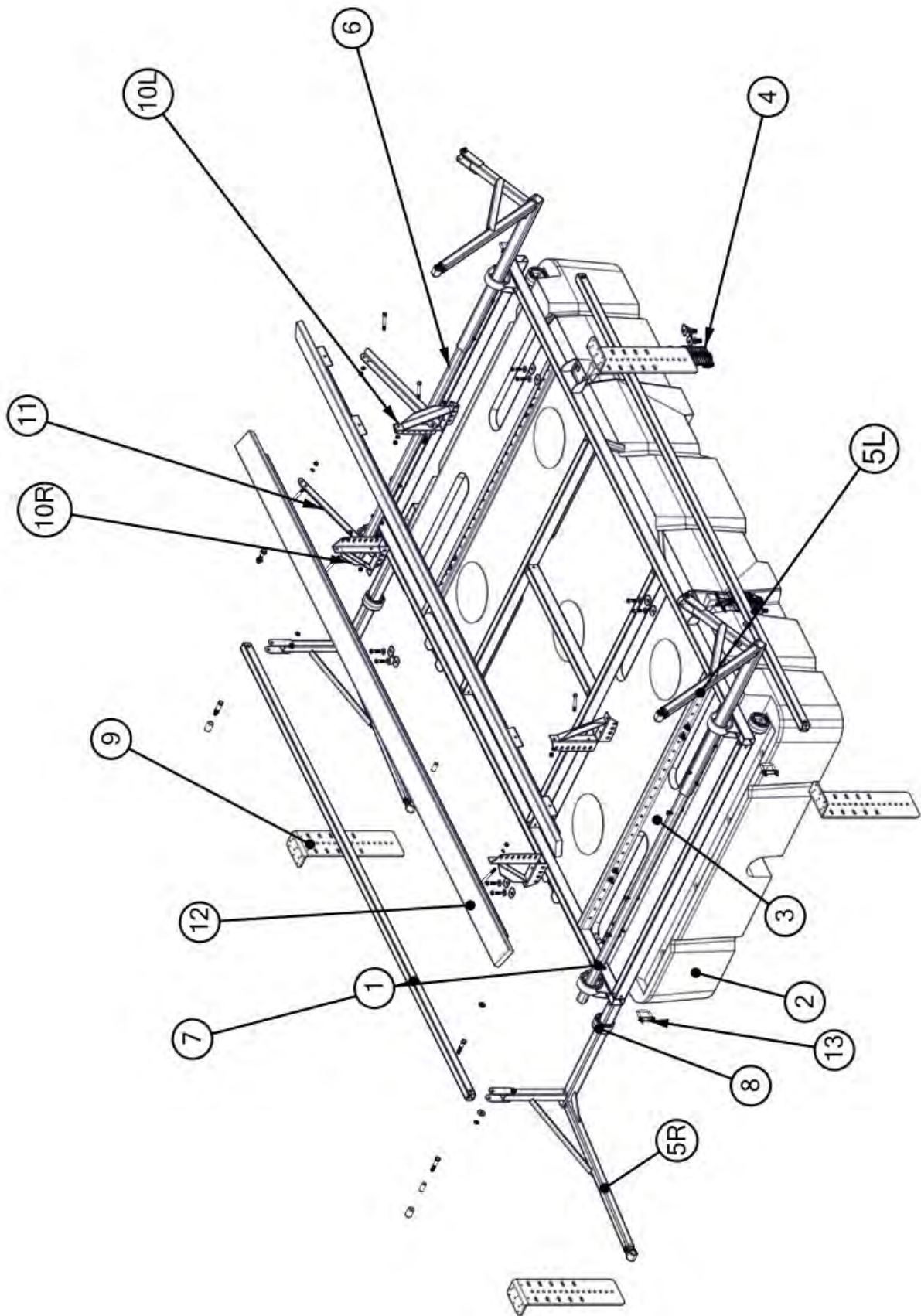

# Pontoon / Tritoon Pad Configuration

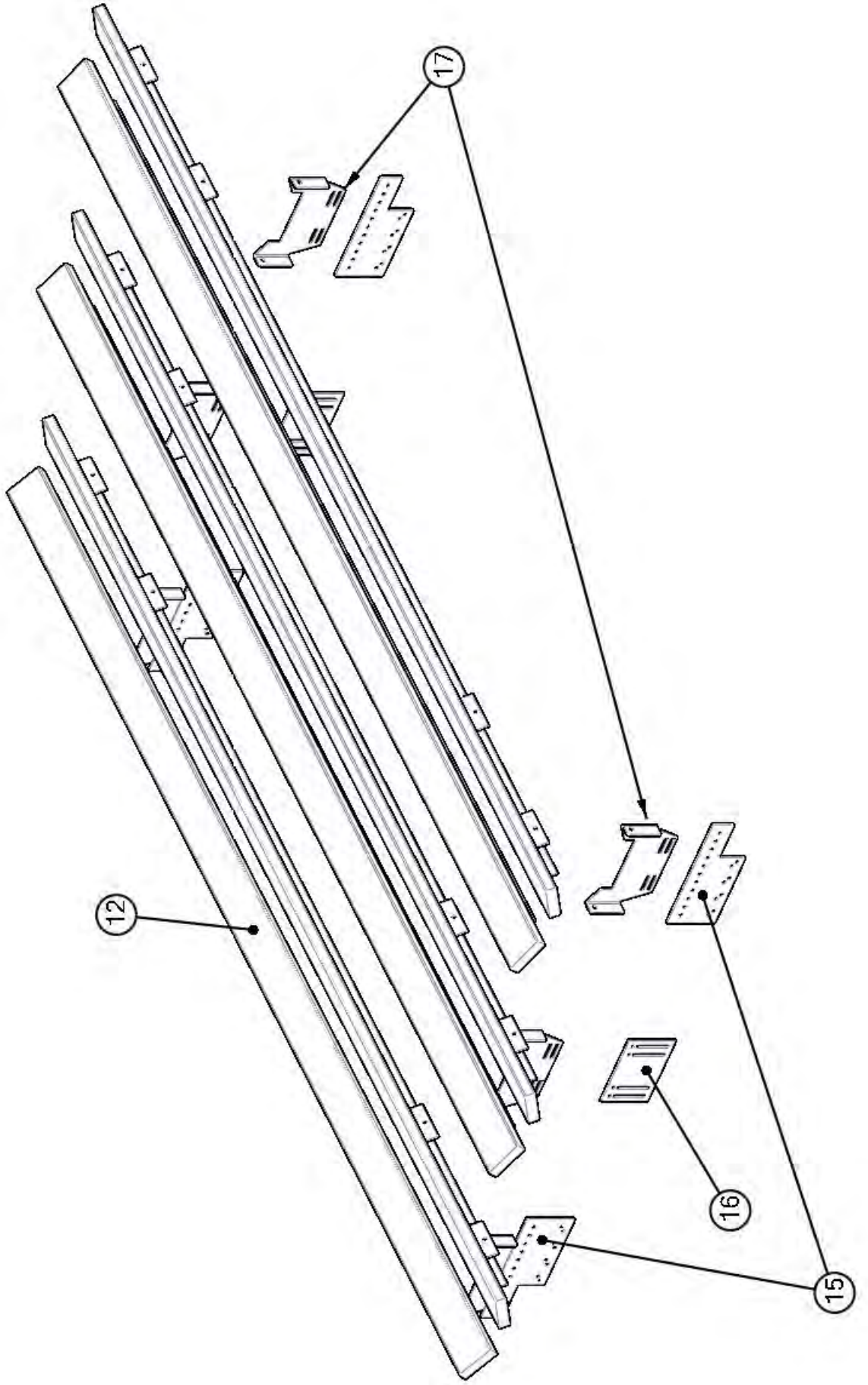



**Attaching the frame to the tank.**

Step	Procedure
1.1	Place frame [1] on tank [2] making sure that the 31" cross member spacing is located at the rear of the tank. The arm bushing cages should be pointed down and nested in the pockets of the tank.
1.2	Attach plastic side brackets [4] to the tank [2]. Bolt the frame to the plastic side brackets using the supplied hardware. [1/2"-13 x 2" bolt (8x), flat washers (36x), sq. washers (8x), side bracket plate (4x), lock washers (8x), and nuts (8x)]

**Torsion Bar and Arm Installation**

Step	Procedure
2.1	Slide torsion bars [6] through one arm bushing cage on the frame. Finish sliding the torsion bars through the other bushing cage until both torsion bars are centered.
2.2	Insert one arm bushing [8] on each Torsion Leg of Stabilizer Arm. Slide the right side arms [5R] onto the torsion bar [6] and then slide the left side arms [5L] onto the torsion bar until they bottom out.
2.3	Drive the arm bushings [8] down the arm tubes and into the frame bushing cages on the frame [1].
<b>IMPORTANT: Never place any part of your body between the lift arms and frame as serious or deadly injury could result. Do not attempt assembly or installation without the help of at least one other person.</b>	

**Hull Pad Assembly V-Hull and Wake Board Only**

Step	Procedure
3.1	Place the hull support columns [10 R/L] on the frame cross channels. The column should be positioned such that the diagonal brace is toward the outside of the hoist. Use the supplied 1/2"-13 x 1 1/2" bolts (8x), washers (16x), lock washers (8x), and nuts (8x) to bolt the columns to the frame. Leave the columns loose until final position is determined.
3.2	Install hull pads [12] to the top of the hull support columns [10] using the supplied 1/2"-13 x 5" bolts (4x), lock washers (4x) and nuts (4x). The side with the angle running down the full length of the pad should be positioned toward the center of the hoist.
3.3	Install the angle support brace [11] using the supplied hardware. [top - shares hardware with step 3.2, bottom - 1/2"-13 x 1 1/2" bolt (2x), lock washers (2x) and nuts (2x)]

**Hull Pad Assembly Pontoon and Tritoon Only**

Step	Procedure
3.1	Bolt the pontoon riser plates [15] to the frame [1] using the supplied 1/2"-13 x 1 1/2" bolts (8x), washers (16x), lock washers (8x), and nuts (8x). For tritoons also bolt the Offset Tritoon Riser plates [16] to the center of the frame [1/2"-13 x 1 1/2" bolts (4x), washers (8x), lock washers (4x), and nuts (4x)]
3.2	Install the pontoon pad brackets [17] to the risers [15&16] using the supplied hardware [1/2"-13 x 1 1/2" bolts (8x/12x), washers (16x/24x), lock washers (8x/12x), and nuts (8x/12x)]. If the location heights are correct these bolts can be tightened at this time.
3.3	Install hull pads [12] to the top of the brackets [17] using the supplied 1/2"-13 x 5" bolts (8x/12x), lock washers (8x/12x) and nuts (8x/12x). The side with the angle running down the full length of the pad should be positioned toward the center of the "v" on each set of pads.

**Pitman Installation**

Step	Procedure
4.1	Attach pitman arms [7] to Arms with 5/8" x 4 1/2" bolts (4x), washers (12x), lock washers (4x), and Lock Nuts (4x) as shown in diagram. Tighten bolts until snug, and then back off 1/8 turn so parts will rotate.

**Final Arm Assembly**

Step	Procedure
5.1	Place 4 - 1/2 " x 1" "set" bolts with jam nut into Arms as shown.
5.2	<i>Place 4 – bushing retainers 1 on each arm outside of the frame next to lift arm bushing. If transporting lift after assembly tighten these retainers to avoid having arms slide out</i>
5.3	When the arms are in their final position, Drill and thru bolt the arms to the torsion tube using the supplied 1/2" - 3" bolt, washers, and nuts.
	<b>IMPORTANT: Never place any part of your body between the lift arms and frame as serious or deadly injury could result. Do not attempt assembly or installation</b>

# Installation Instructions

**Locate the rear dock bracket position**

Step	Procedure
1.1	A good general rule for boats under 20' long is to locate the rear dock bracket back from the front of the slip a distance equal to the boat length (not including any swim platform length). With longer boats you may need to have some of the boat off the back of the lift to achieve proper weight distribution. Please contact us with boat length, type, brand of boat, and slip size and we can advise you of where to locate the lift in the slip if needed. The key to proper lift operation is getting the boat balanced so that the weight is evenly distributed over the lift tank. Generally with v hull boats this is achieved when the transom is inline with the rear of the lift. Pontoons and Tri-toons however may have 2-3 feet of the boat overhanging the lift in order to get the lift to set level.

**Locate the front dock bracket position**

Step	Procedure
2.1	Measure from the rear of the back dock bracket forward 144". This will be the location of the rear of the front bracket. The brackets should then be located on 144" centers.
2.2	Attach the dock brackets to the dock at the closest point to water level as possible. It is best to drill through the dock bracket and the dock and attach with no smaller than 2 - 3/8" bolts. Attach the top of the dock bracket either in the top with the holes provided or drill your own in the side as close to the top of the bracket as possible with no less than 2 - 3/8" bolts. All 4 dock brackets should be attached in this manner.

**Connect the Arms to the dock brackets**

Step	Procedure
3.1	Connect the arms to the dock brackets using the 5/8" bolts (4x), nuts (4x), washers (8x), and lock washers (4x) provided. Tighten all four bolts.
	<b>IMPORTANT: Never place any part of your body between the lift arms and frame as serious or deadly injury could result. Do not attempt assembly or installation</b>

**HydroGuards—If Lift is equipped with optional Heavy Duty Dock Brackets (5049000)**

*Fig. S*

Step	Procedure
4.1	Attach HydroGuard[27] to the Dock Bracket Vertical Angle [25] in the 3rd hole above the arm bolt, or the 7th hole below the arm bolt, depending on arm location along vertical angle[25]. Fasteners per HydroGuard: (2 ea) 5/8" x 4" bolt, nut and lockwashers. Tighten to 20 ft. lbs.

**Fig. S**

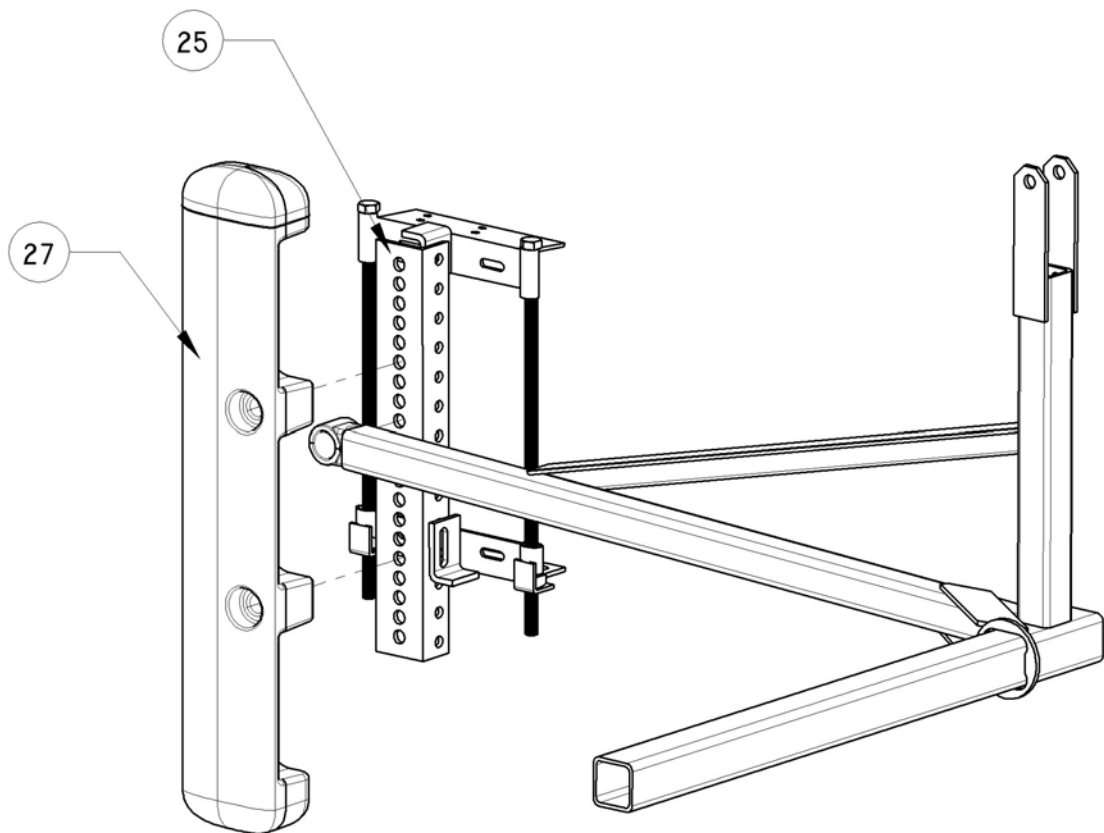

**Center the lift in the slip**

Step	Procedure
4.1	Center the lift in the slip by sliding the frame on the arms until the frame is an equal distance from the dock on both sides. To hold the frame centered slide the retainers on the arms against the bushings in the frame that the arms slide through and tighten all four retainers.

**Leveling the Lift**

Step	Procedure
5.1	Level the lift using the water as a level. You can step on or bounce the lift down as needed to level it out. Tighten the 1/2" set bolts in arms first in back, then in front. Once all four are tight - tighten the "jam" nut to lock the bolt in place. Drill through and place (2) 3/8" X 3 1/2" Bolts on each side of the set bolts approximately 12" apart. Tighten with Lock Washers and Nuts provided.
	<b>IMPORTANT: Never place any part of your body between the lift arms and frame as serious or deadly injury could result. Do not attempt assembly or installation</b>
	<b>IMPORTANT: DO NOT PUT BOAT ON LIFT BEFORE DRILLING AND BOLTING ARMS!        Serious damage and/or injury may result!</b>

**Adjust the Hull Pads**

Step	Procedure
6.1	Adjust the hull pads to match the bottom of the boat or pontoon. The best way is to measure off of the boat. If the boat is not available measure from the side of the frame to the center of the bracket 19" in the back and 18" in the front for a runabout or proper centers for your pontoon. Tighten hull pad bolts.

**Connect the lift to the Control unit**

Step	Procedure
7.1	Put sealant on hose nipple and screw into tank flange. Do not over tighten.
7.2	Attach hose to the tank nipple with sealant and #20 hose clamp, tighten securely.
7.3	Submerge lift and cut hose to length to reach the lift control unit location.
7.4	Attach hose to the control unit using sealant and hose clamp
7.5	Mount control unit to dock.

**Test Lift Operation**

Step	Procedure
8.1	Pull boat in slip over lift.
8.2	Hold boat away from front of dock about 12 to 18 inches.
8.3	Turn control unit on and turn handle to the raise lower position. As lift rises it will travel forward in the boat slip, so watch the front of the boat to make sure it does not hit the dock when coming up.
8.4	When lift is to desired height or tank is full of air, turn handle back to the closed position and turn off motor.
8.5	If the lift operated properly and balanced, lower the boat back into the water making sure to hold it in position. Install guide ropes. Ropes should be installed so they are snug when the boat is the proper position for lifting. The ropes should be free to move through the travel of the lift while lifting.

# V-Hull and WakeBoard Parts List

Item #	Part #	Part Description	Qty
1	EL-1050	Frame	1
2	EL-1060	Tank	1
3	2091204	Hose Nipple	1
4	4210001	Tank Side Bracket	4
5R	EL-1110	Arm Right	2
5L	EL-1120	Arm Left	2
6	3050730	Torsion Tube	2
7	EL-1030	Pitman Arm	2
8	2916730	Arm Bushing	4
9	EL-1016	E-Series / Low Profile Dock Bracket	4
10R	4031100	Hull Pad Support Column W/ DOT	2
10L	4031110	Hull Pad Support Column W/O DOT	2
11	3031700	Angle Support Brace	2
12	5025600	Hull Pad	2
13	EL-1061	Bushing Retainer Assembly	4
14	EL-1036	KIT BOX - STANDARD LIFT KIT	1

## OPTIONAL HEAVY DUTY DOCK BRACKETS

Item #	Part #	Part Description	Qty
25	5049000	Dock Bracket—Heavy Duty	4
26	6916500	Kit—Hardware Hydroguard	1
27	5203500	Hydroguard—Blue	4

# Pontoon and Tri-toon Parts List

Item #	Part #	Part Description	Qty
1	EL-1050	Frame	1
2	EL-1060	Tank	1
3	2091204	Hose Nipple	1
4	4210001	Tank Side Bracket	4
5R	EL-1110	Arm Right	2
5L	EL-1120	Arm Left	2
6	3050730	Torsion Tube	2
7	EL-1030	Pitman Arm	2
8	2916730	Arm Bushing	4
9	EI-1016	E-Series / Low Profile Dock Bracket	4
12	5025600	Hull Pad	4/6
13	EL-1061	Bushing Retainer Assembly	4
14	EL-1036	Kit Box - Standard Lift Kit	1
15	3031525	Pontoon Riser Plate	4
16	3031520	Offset Tritoon Riser Plate	2
17	4032100	Pontoon Pad Bracket	4/6
18	6907001/2	Kit Bag - Pontoon / Tritoon	1

## OPTIONAL HEAVY DUTY DOCK BRACKETS

Item #	Part #	Part Description	Qty
25	5049000	Dock Bracket—Heavy Duty	4
26	6916500	Kit—Hardware Hydroguard	1
27	5203500	Hydroguard—Blue	4